

Towards a New Antarctic Architecture : Terra Nova II Expedition

by

Taylor Gray Medlin

B.E.D.A (North Carolina State University) 2006

A thesis submitted in partial satisfaction of the

requirements for the degree of

Master of Architecture

in the

Graduate Division

of the

University of California, Berkeley

Committee in charge:

Professor Ron Rael, Chair

Professor Rene Davids

Professor Walter Hood

Spring 2010

change to "Ronald
Rael"

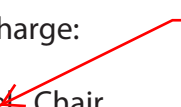

The thesis of Taylor Gray Medlin is approved:

Chair _____ Date _____

_____ Date _____

_____ Date _____

University of California, Berkeley

Towards a New Antarctic Architecture : Terra Nova II Expedition

© 2010

by Taylor Gray Medlin

Abstract

Towards a New Antarctic Architecture : Terra Nova II Expedition

by

Taylor Gray Medlin

Master of Architecture

University of California, Berkeley

Professor Ron Rael, Chair

change to "Ronald Rael"

The "Terra Nova II expedition" will be departing from Berkeley, CA for the distant shores of Antarctica on May 14th, 2010 to attempt to survive and thrive in one of the most inhospitable locations in the world. The definition of an expedition is "a journey undertaken by a group of people with a definite objective." For all of those brave souls that volunteer for the expedition, our objective will be to prove the plausibility and usefulness of construction in Antarctica using only a minimum amount of resources and materials for comfortable habitation.

Antarctica's isolated location results in a gross misuse of materials from a construction and logistical point of view. Not only does every scrap of material used to build have to be flown over from the mainland, but when a building deteriorates {usually within 10 years} that same material has to be hauled all of the way back out of Antarctica. Together, as a coalition, we will prove that it is not only possible to build in Antarctica with minimal external resources, but that it is the beginning of a new age of construction for the continent!

Chair_____ Date_____

to my family
for always believing in me,
or at least telling me you did.

TABLE OF CONTENTS

Prologue : A Brief History of TANAAC

{1} Encountering World's End

{2} Life Support Modules

{3} ICE 9 System

{4} Habitation Pods

{5} The ARK

Epilogue: A New Future

Appendix: Data

TOWARDS A NEW ANTARCTIC ARCHITECTURE

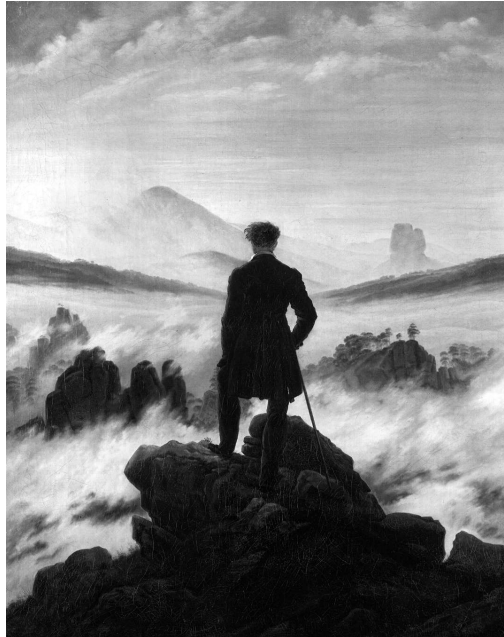

“With other men, perhaps, such things would not have been inducements; but as for me, I am tormented with an everlasting itch for things remote. I love to sail forbidden seas, and land on barbarous coasts. Not ignoring what is good, I am quick to perceive a horror, and could still be social with it- would they let me- since it is but well to be on friendly terms with all the inmates of the place one lodges in.

By reason of these things, then, the whaling voyage was welcome; the great flood-gates of the wonder-world swung open, and in the wild conceits that swayed me to my purpose, two and two there floated into my inmost soul, endless processions of the whale, and, mid most of them all, one grand hooded phantom, like a snow hill in the air.”

-Herman Melville

ACKNOWLEDGEMENTS

in text, i prefer my full name, but in this case it's ok, since my friends call me ron. thank you for the great project. it was an amazing experience.

This thesis owes an enormous debt to Ron Rael for all of his tireless support, enthusiasm, and late-night/early-morning e-mails. Thank you for your kind words on hard days and pushing the project to a place that it would have never gotten without your guidance.

Special thanks to Rene Davids, Gary Black, Zoe Prillinger and Luke Ogrydziak for taking even the bad ideas seriously, but more importantly, laughing at the good ones.

Heartfelt thanks are also owed to Gavin Knowles, Megan Johnson, Peter Lingamfelter, Ben Gold-er, Nick Sowers, Rocky Hanish, and Dave Bowen for scripts, scrolls, fictitious histories, breakfast conversations, Kahn/Thesis talks, and dressing up in jump suits {respectively}.

PROLOGUE : A BRIEF HISTORY OF T.A.N.A.A.C.



VOLUNTEERS WANTED

**FOR HAZARDOUS JOURNEY,
SMALL WAGES, BITTER COLD,
LONG MONTHS OF
COMPLETE DARKNESS,
CONSTANT DANGER,
SAFE RETURN DOUBTFUL,
ARCHITECTURAL HONOR AND
RECOGNITION IN CASE OF
SUCCESS.**

Come get cold,



Founder T.A.N.A.A.C.

A "warm" thanks to all of our generous sponsors.





Expedition : a journey undertaken by a group
of people with a definite objective

Come one, come all to sign up for the journey of a lifetime! The “**Towards A New Antarctic Architecture Coalition**” {**T.A.N.A.A.C.**} is currently accepting applications for their forthcoming expedition, the **TERRA NOVA II EXPEDITION**. The expedition will be leaving on May 14th from Berkeley, California and will be making its way down to the southernmost continent in the world, Antarctica. For all of those brave souls that volunteer for the expedition, our objective will be to prove the plausibility and usefulness of construction in Antarctica using only a minimum amount of resources and local materials for comfortable habitation.

The origins of **T.A.N.A.A.C.** are unclear at best. However, some facts do persist. It is believed that the Coalition’s roots can be traced back to the fifteenth century to explorers such as Bartolomeu Dias in 1487 and Garcia de Nodal in 1619, but the first documented member was the English explorer Captain James Cook of the Royal Navy. Cook was the first to confirm the existence of a southern polar land mass in 1773 and came within 75 miles of it before encountering adverse ice flows and turning back. Other explorations by the English continued with little success until, in 1820, Edward Bransfield, on behalf of King George III and **T.A.N.A.A.C.**, became the first to discover and document the land known today as Antarctica. Other members of **T.A.N.A.A.C.** like Robert Falcon Scott and Earnest Shackleton continued to explore in an effort

to first set foot on the South Pole. In efforts to achieve this goal, Scott's exploration is one of the most memorable and sobering tales in the history of **T.A.N.A.A.C.** After many journal entries of the slowing Terra Nova I expedition, the four men including Scott were subjected to some of the most extreme conditions ever recorded in the region. As Scott's final journal entry records:

"Every day we have been ready to start for our depot 11 miles away, but outside the door of the tent it remains a scene of whirling drift. I do not think we can hope for any better things now. We shall stick it out to the end, but we are getting weaker, of course, and the end cannot be far. It seems a pity but I do not think I can write more. R. Scott. For God's sake look after our people."

In 1926, Richard Evelyn Byrd became the first American member of **T.A.N.A.A.C.** As an officer of the United States Navy, he pioneered the exploration of the continent by air. Since then, the United States, Great Britain, Norway, Australia, and New Zealand have all been strong representatives of **T.A.N.A.A.C.** and its legacy of Antarctic exploration. As the centuries have passed and as the centuries continue, **T.A.N.A.A.C.'s** efforts help lead the way towards habitats upon the Southern continent and through partnerships with organizations like The International Polar Foundation and The Hanso Foundation, the future remains focused on a commitment to encouraging excellence in architecture, science, and technology and furthering the cause of human development. As one of our earliest members poignantly wrote centuries ago:

"It was, indeed, my opinion, as well as the opinion of most on board, that this ice extended quite to the pole, or perhaps joined on some land, to which it had been fixed from the earliest time. I had ambition not only to go farther than any one had been before, but as far as it was possible for man to go. Desolate, bleak, and barren was the path of our journey, but above all, cold."

-Captain James Cook

January 30, 1775 : lat 71° 10' S., long 106° 54' W.

{1} ENCOUNTERING WORLD'S END

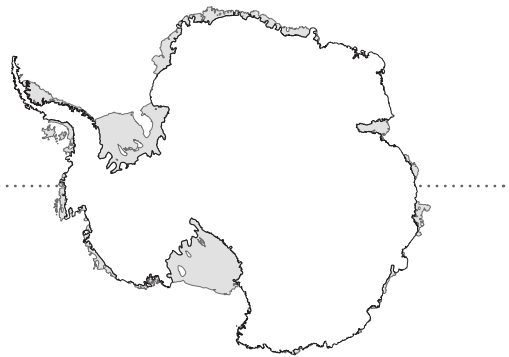



Antarctica is familiar to all as a remote location with some of the harshest conditions confronted by humankind on the face of the earth. The average temperature hovers around -30°F year round and can get to -70°F with wind chill factored in. Wind speed averages about 20mph year round from a primarily northern orientation¹. Byrd Station, where most of the relevant climate data comes from is at an altitude of 5,020 ft. Visibility is often reduced to a few feet in front of your face, as there are blizzards almost 150 days a year². Frostbite can occur within seconds, not hours, and is so common on the extremities that most “year-rounders” don’t even bothering reporting it. Wind speeds average 20 mph and in some places blizzards occur over half of the days in the year, decreasing visibility to often inches in front of your face {See Fig. 1}. There are about 4000 people living in Antarctica during the summer, and the number drops down to 1000 during the winter, where those staying have to submit to extensive psychologi-

can they come from any other direction??

1 wind data obtained from “The Weather Network’s” antenna at Byrd Station : <http://www.theweathernetwork.com/index.php?product=statistics&pagecontent=C03594>

2 information obtained from The International Antarctic Weather Forecasting Handbook : http://www.antarctica.ac.uk/met/momu/International_Antarctic_Weather_Forecasting_Handbook/index.php

FIG. 1 : SITE ANALYSIS

SUMMER

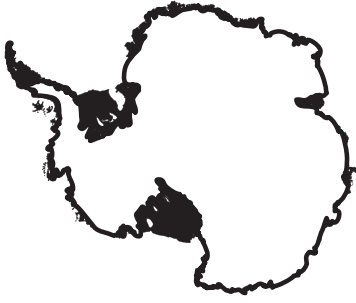

SEA ICE EXPANSION



WINTER

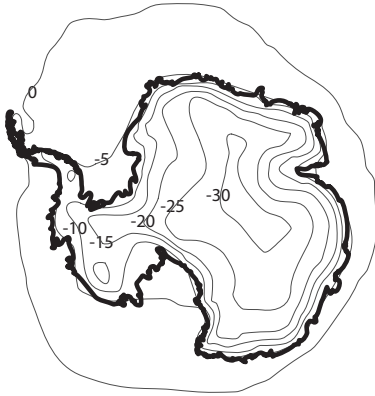

AVERAGE TEMPERATURE

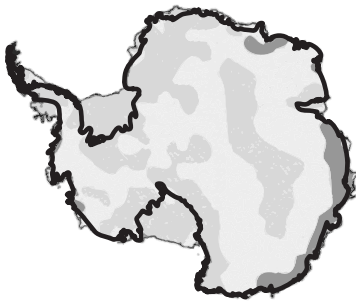
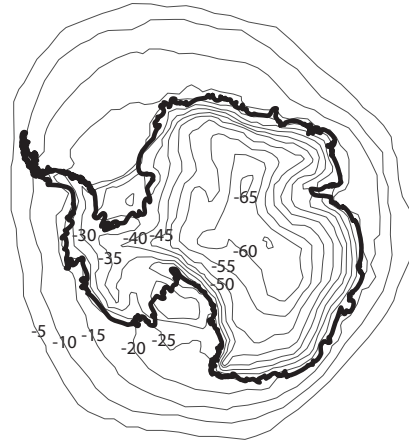

AVERAGE WIND VELOCITY

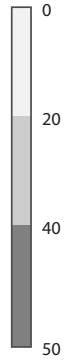
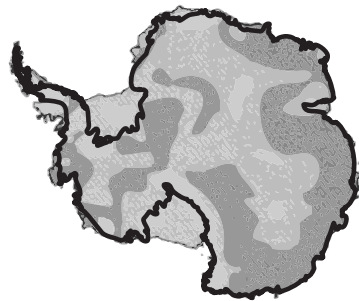

ANTARCTIC SITE MAP WITH RESEARCH STATION LOCATIONS

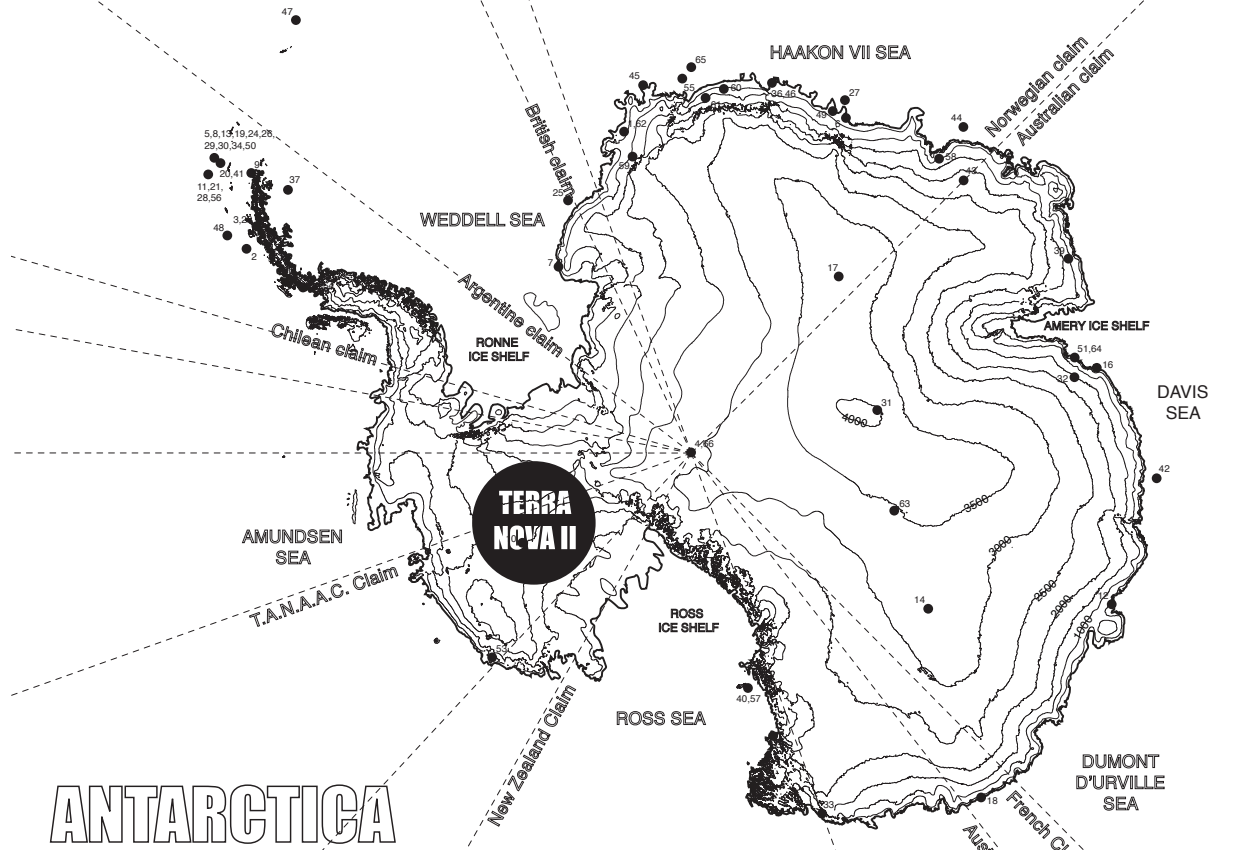

ANTARCTICA

- | | |
|--|---|
| <ol style="list-style-type: none"> 1. ABOA (FINLAND) 2. VERNADSKY RESEARCH BASE (ARGENTINA) 3. ALMIRANTE BROWN ANTARCTIC BASE (ARGENTINA) 4. AMUNDSEN-SCOTT SOUTH POLE STATION (USA) 5. ARTIGAS BASE (URUGUAY) 6. ASUKA STATION (JAPAN) 7. BELGRANO II (ARGENTINA) 8. BELLINGSHAUSEN STATION (RUSSIA) 9. BERNARDO O'HIGGINS STATION (CHILE) 10. BYRD STATION (USA) 11. CAPTAIN ARTURO PRAT BASE (CHILE) 12. CASEY STATION (AUSTRALIA) 13. COMANDANTE FERRAZ BRAZILIAN ANTARCTIC BASE (BRAZIL) 14. CONCORDIA STATION (FRANCE, ITALY) 16. DAVIS STATION (AUSTRALIA) 17. DOME FUJI STATION (JAPAN) 18. DUMONT D'URVILLE STATION (FRANCE) 19. BASE PRESIDENTE EDUARDO FREI MONTALVA (CHILE) 20. ESPERANZA BASE (ARGENTINA) 21. GABRIEL DE CASTILLA SPANISH ANTARCTIC STATION (SPAIN) 23. GONZALEZ VIDELA STATION (CHILE) 24. GREAT WALL STATION (CHINA) 25. HALLEY RESEARCH STATION (UNITED KINGDOM) 26. HENRYK ARCTOWSKI POLISH ANTARCTIC STATION (POLAND) 27. JINNAH ANTARCTIC STATION (PAKISTAN) 28. JUAN CARLOS I BASE (SPAIN) 29. JUBANY (ARGENTINA) 30. KING SEJONG STATION (SOUTH KOREA) 31. KUNLUN STATION (CHINA) 32. LAW-RACOVITA STATION (ROMANIA) 33. LENINGRADSKAYA STATION (RUSSIA) 34. MACHU PICCHU RESEARCH STATION (PERU) | <ol style="list-style-type: none"> 35. MACQUARIE ISLAND STATION (AUSTRALIA) 36. MAITRI STATION (INDIA) 37. MARAMBIO BASE (ARGENTINA) 38. MARIO ZUCHELLI STATION (ITALY) 39. MAWSON STATION (AUSTRALIA) 40. MCMURDO STATION (USA) 41. MENDEL POLAR STATION (CZECH REPUBLIC) 42. MIRNY STATION (RUSSIA) 43. MIZUHO STATION (JAPAN) 44. MOLODOZHNYAYA STATION (RUSSIA) 45. NEUMAYER STATION (GERMANY) 46. NOVOLAZAREVSKAYA STATION (RUSSIA) 47. ORCADAS BASE (ARGENTINA) 48. PALMER STATION (USA) 49. PRINCESS ELISABETH BASE (BELGIUM) 50. PROFESSOR JULIO ESCUDERO BASE (CHILE) 51. PROGRESS STATION (RUSSIA) 52. ROTHERA RESEARCH STATION (UNITED KINGDOM) 53. RUSSKAYA STATION (RUSSIA) 54. SAN MARTIN BASE (ARGENTINA) 55. SANAE IV (SOUTH AFRICA) 56. ST. KLIMENT OHRIDSKI BASE (BULGARIA) 57. SCOTT BASE (NEW ZEALAND) 58. SHOWA STATION (JAPAN) 59. SVEA (SWEDEN) 60. TOR STATION (NORWAY) 61. TROLL STATION (NORWAY) 62. WASA STATION (SWEDEN) 63. VOSTOK STATION (RUSSIA) 64. ZHONGSHAN (SUN YAT-SEN) STATION (CHINA) 65. KOHNEN-STATION (GERMANY) 66. WILLARD RESEARCH STATION - ICE CORE STUDY (USA) |
|--|---|



TYPICAL CONSTRUCTION



DETERIORATION DUE TO SNOW

cal testing to make sure their minds and bodies can survive the dark days and incredibly cold temperatures³.

So it should come as no surprise that two of the biggest challenges to current research stations in Antarctica are building construction and longevity, as well as the ability to continuously heat the interior spaces from the sub-zero temperatures. An average building in Antarctica lasts about 10 years, and most large stations take roughly three years to construct {The why the use of brackets here? Amundsen Scott base at the South Pole took 12 years to finish!⁴}. Comparing the lifespan of the buildings to their time needed for construction highlights their incredibly high life cycle cost, with the construction alone sometimes taking half the amount of time as the overall life. The constant erosion of the stations happens for multiple reasons.

The exterior of the buildings are prone to constant high winds, buffeted from almost

.....
3 Piantadosi, Claude E. *The Biology of Human Survival: Life and Death in Extreme Environments* {New York, New York : Oxford University Press, Inc., 2003}

4 Slavid, Ruth. *Extreme Architecture: Building for Challenging Environments* {London, England : Laurence King Publishing Ltd., 2009}

all sides with cold snow and ice. The ice then gets into the joints of buildings and expands, making almost any area susceptible to deterioration. Building materials in Antarctica tend to be shockingly similar to those used in the United States, with even plywood being used as an exterior cladding in many Australian buildings at McMurdo, the largest settlement in Antarctica, with over 1200 people during the summer. Understandably, the construction techniques that seemed to work so well in the Northern Hemisphere are rendered ineffective down South, calling even more attention to the lack of any truly “Antarctic architecture”.

can you expand on why this is shocking?

Heating is another huge concern, and is primarily done by super-insulating the building to roughly four times the R-value of buildings in the States. The temperature outside can get down to -70°F , while the interior temperature is usually kept around 65°F . That means there is almost a one hundred and forty degree difference from the inside to outside that is mitigated by a thin 8 inch wall construction. The power necessary to make up this drastic temperature swing is substantial, and most all electricity on the continent still comes from diesel generators, powered by fuel hauled over laboriously from the mainland.

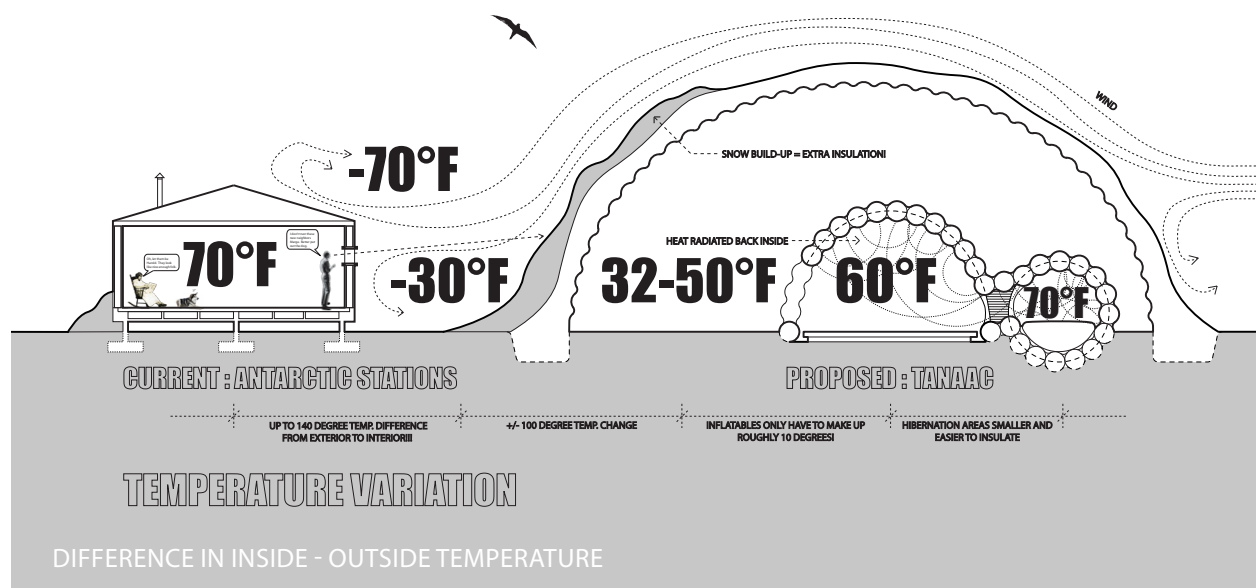

“Condition One Weather.” ~~That~~ is the technical term for white out weather in Antarctica. During Condition One you are not allowed to leave the confines of the interior of the building due to extremely strong winds, low visibility, and sub-sub-zero temperatures right on the other side of the door. The amount of mechanical units and insulation necessary to mitigate this huge differential requires large amounts of energy and material, and because of their one layer approach to interior/exterior, a majority of the buildings deteriorate almost five times as quickly as a similar construction on the mainland.

As a counter to the normally accepted one layer wall system, the **TERRA NOVA II EXPEDITION** proposes to stretch the line between interior and exterior into a slowly changing temperature gradient. Consisting of a three part construction system **T.A.N.A.A.C.** is proposing an **ICE 9 SYSTEM, HABITATION PODS,** and **LIFE SUPPORT UNITS** {outlined in detail later in this report}. Directly inside the **ICE 9 SYSTEM,** a wall construction made from local materials, the temperature is brought above freezing through fundamental igloo principles of trapping heat and using built up snow as an insulator on the outside⁵.  the warmer air inside melts the inner ice layer, it is refrozen instantly because of the extremely cold outside temperature, thereby creating a continuous surface that is able to trap and retain a certain amount of heat. Warm air blown into the **HABITATION PODS** from the **LIFE SUPPORT UNITS** allows the inflatables to remain at relatively constant temperatures by not having to make up the extreme temperature differences from outside.

.....
5 Yankielun, Norbert E. *How to Build an Igloo* {New York, New York : W. W. Norton & Company, 2007}

{2} LIFE SUPPORT MODULES

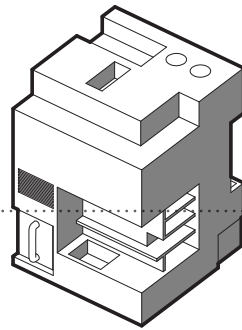

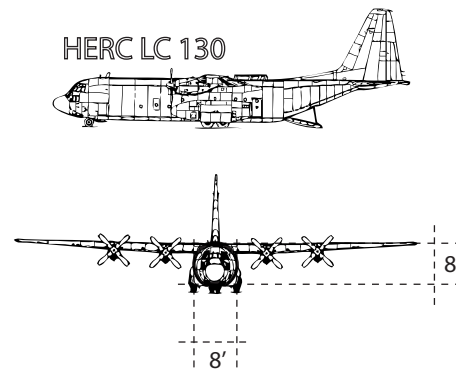
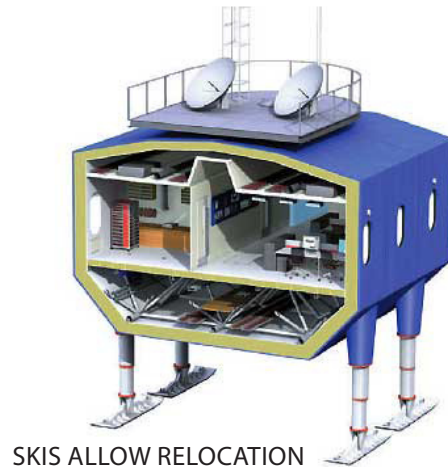

FIG. 2 HERC DIMENSIONS

Antarctica poses incredibly difficult logistical concerns for the transporting of materials back and forth from the continent. The “Hercules LC 130” outfitted with skis is one of the few planes that can safely land on Antarctica given the runway conditions and logistical concerns. The cargo hold of the aircraft is 8’ wide x 8’ tall x 38’ long, and it can hold a maximum carry weight of 155,000 pounds, meaning the size and weight of materials is severely limited {See Fig. 2}. Lightness and efficiency then become key words when thinking of what to prefabricate off-site when building in Antarctica.

A majority of the buildings in McMurdo {the largest settlement in Antarctica} are completely site-built due to size restrictions transporting the material, though many do arrive with uncomplicated building assemblies to make construction faster. Outside of McMurdo however, there are examples of research stations being designed to take advantage of prefabrication, the British Halley VI Antarctic Station and the American Amundsen-Scott Station. Both research stations are very recent projects, being currently constructed, and completed in 2003, respectively. At the Halley VI Antarctic Station, the site for the project is on the Brunt Ice Shelf, an incredibly difficult bit of topography to work with, as the land itself is in constant motion,



moving up to 400 meters a year towards the ocean. Beyond that, the area receives three feet of snow a year, a lot even in Antarctica's standards. So the proposed building had to be able to deal with shifting conditions underneath as well as not become buried by the build-up of snow over the course of the year. The solution in their case was to create a modular system of fabrication that could be transported and quickly put together on site, as well as added onto over time. Another benefit of the construction method is that it allows the modules to be built close to the coast where they are delivered, then actually relocated to the site (each large module is outfitted with skis to allow for movement on flat ice)¹.

Another research station that takes advantage of a flexible construction technique is the Amundsen-Scott South Pole Station. It is the largest single research station in Antarctica, able to contain 154 personnel in the summer, and 50 in the winter. Like the location of Halley VI, the South Pole receives a plethora of snow each year, necessitating some way to deal with snow build-up. Unlike the British station however, Amundsen-Scott is not movable horizontally, rather it has the ability to be jacked up vertically on its stilts, up to 3 stories high from its initial starting position! {See Fig. 3} Since it is in such an isolated location, all materials had to be

1 Slavid, Ruth. *Extreme Architecture: Building for Challenging Environments* (London, England : Laurence King Publishing Ltd., 2009)



FIG. 3 : AMUNDSEN-SCOTT SOUTH POLE STATION

hull of the LC 130. While these examples took some liberties with new construction typologies in Antarctica, they were still incredibly limited in scope by the non-questioning use of standard materials as well as lengthy construction process {Halley VI has already taken 3 years and looks not to be completed in the expected time frame of 2010}². How can future habitations be designed in a way where they take advantage of the flexibility of site built construction while retaining the speed available through prefabrication?

Buildings in Antarctica currently fragment all of their utilities, necessitating countless superfluous meters of piping/ductwork that have to weave their way through complex wall systems. Why not load all of those messy utility functions into one place, allowing units to be completely prefabricated on the mainland and shipped to site in one go? Once placed on site, crucial facilities such as rest rooms and cooking stations would be instantly online to provide utilities and power for the construction process as well as the eventual habitation.

.....
 2 More info on the status of Halley VI can be found @ http://www.antarctica.ac.uk/living_and_working/research_stations/halley/halleyvi

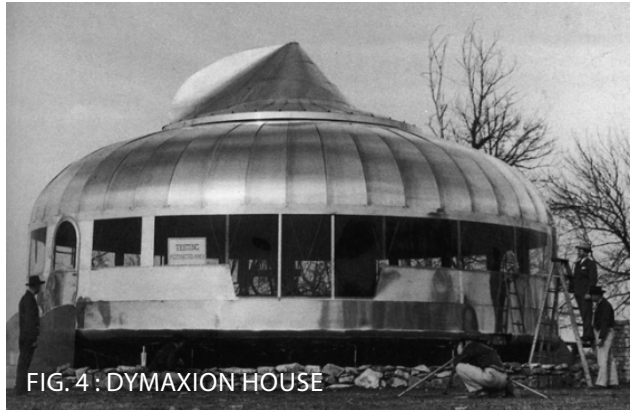

FIG. 4 : DYMAXION HOUSE



FIG. 5 : TROPICAL HOUSING

In the **TERRA NOVA II EXPEDITION**, prefabricated procedures are used to hasten on-site construction as well as limit material waste. Over the course of the past 3 months, **T.A.N.A.A.C.** members have been working tirelessly in the Port city of Punta Arenas, Chile to produce a series of initial **LIFE SUPPORT MODULES** that will be ready for pick-up and transportation down to Antarctica in the coming weeks. The advantages of prefabrication for housing as well as disaster relief have been explored in depth by architects and inventors such as Buckminster Fuller and Jean Prouve, with their prototypes for Dymaxion houses³ and tropical housing⁴ {See Fig. 4 & 5}. Lightness, as well as the ability to be quickly installed on site are just two of the many advantages offered by producing the modules off-site and then delivering them directly to the destination.

The proposed **LIFE SUPPORT MODULES** are made up of materials able to withstand the wear and tear of the extreme conditions prevalent in Antarctica, and are dimensioned to fit snugly within the cargo hold of the LC 130. They use the principles of “blocks” seen in Kieran-Timberlake’s Loblolly house, which are units that “contain mechanical and electrical manifolds that organize and manage all incoming and outgoing utility connections.”⁵ {See Fig. 6} The

3 Sieden, Lloyd. *Buckminster Fuller’s Universe: His Life and Work* {New York, New York : Basic Books, 2000}

4 Von Vegesack, Alexander. *Jean Prouve: The Poetics of Technical Objects* {Vitra Design Stiftung, 2005}

5 Kieran, Stephen and James Timberlake. *Loblolly House* {New York, New York : Princeton Architectural Press, 2008}



“blocks” contain all of the energy and labor intensive services that ultimately lead to such long construction times in other situations, plumbing, mechanical, and electric services. By modulating the most resource heavy components, valuable time can be saved during the actual process. A vast number of different combinations are possible by combining different functions, as can be seen from Fig. 7, putting together bathroom units, kitchens, utilities as the conditions warrant. All of the different principles of resource conservation discussed can be best seen by loading all of the most valuable energy resources in one location that can easily be manufactured off-site before arrival in Antarctica.

FIG. 7 : POSSIBLE **LIFE SUPPORT MODULE** COMBINATIONS

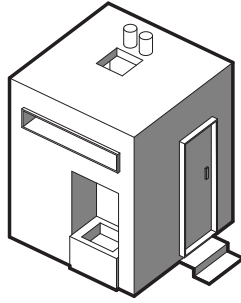

WET ROOMS

What better way to keep pipes to a minimum and make them less likely to freeze? Put them all in one place of course! Sinks, toilets, showers, even a bidet {if it's a European station}, all in one neatly packaged container. Keeping utilities tight also allows for the possibility to capture and retain the heat given off during energy intensive activities like showering.

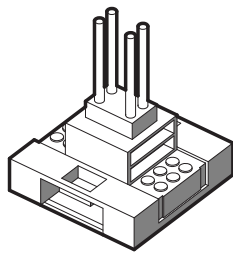

FOOD PREPERATION

All of the cooking and food preparation can be done at the **LIFE SUPPORT STATIONS**. Any sort of oily, greasy, messy work is all contained in one area, making clean up incredibly easy, as well adding something incredibly difficult to achieve with a kitchen, namely mobility. For the celebration of the 25th year anniversary of **T.A.N.A.A.C.** we can gather multiple stations together to cook for all of the guests!

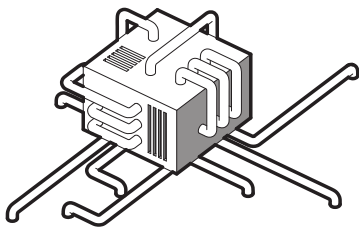

POWER/HEATING

Initially, we'll be running off of diesel generators until other forms of power become accessible. During the summer months, solar power is possible for hot water heating and limited active solar, plus given the constant blizzards, wind will be available in plenty. The **LIFE SUPPORT MODULES** will provide the **HABITATION PODS** with warm air, inflating the pods while also heating the space at the same time!

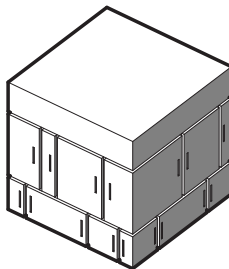

DRY STORAGE

Cold storage is easy, burrow down into the ice, eliminating the need for refrigeration, but dry storage is a different ball game. In order to provide ample storage space for all of the members of **T.A.N.A.A.C.**, units will be provided to hold personal effects as well as any of the more sensitive scientific and construction equipment. Multiple units can even be stacked next to each other for partitioning of space.

{3} ICE 9 SYSTEM

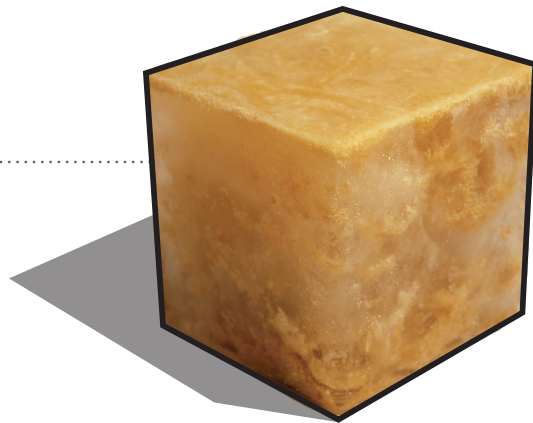



FIG. 8 : THE ICE PALACE OF EMPRESS ANNA IVANOVNA

Construction in Antarctica has long overlooked the possibility of using its one local resource as a building material, namely, **ICE**. Historically, ice as a construction material is predominantly used in short term buildings as a spectacle or attraction, its relative low insulation and temporality not deeming it useful for permanent habitation. Even the first “ice palace” was seen as a place for punishment, when in 1740 two newlyweds that had angered Empress Anna Ivanovna of Russia were made to spend their wedding night in a structure of ice that measured twenty meters tall and fifty meters wide.¹ {See Fig. 8} In contemporary times, there are numerous annual ice hotels and festivals constructed every year, such as the ICE HOTEL in Sweden, the Hôtel de Glace in Canada, the Bjorli Ice Lodge in Norway, and the Harbin Festival in China. These hotels open to the public are incredibly recent inventions, the first ice hotel being constructed in 1992 and mark a new public willingness to rethink living in structures of ice. Not content at stopping with hotels, there is even talk of constructing an entire city of ice by 2012

.....
1 Curtiss, Mina Kirstein. *A Forgotten Empress: Anna Ivanovna and Her Era, 1730-1740* {New York, New York : Ungar Publishing, 1970}



FIG. 9 : METAL FORM WORK FOR ICE HOTEL



CUTTING ICE OUT OF A FROZEN RIVER

in Jukkasjarvi, Sweden.² Though ice hotels as they exist now are only temporary constructions when it is cold enough to prevent melting, once all of the visitors leave the structures return to the earth from where they came, ultimately leaving a blank slate by the time winter comes again next year. No building waste, no scarring and reshaping of the land like even the most sensitive modern dwellings. 

In terms of construction, most ice hotels are built using two different methods. The first is to use large metal forms with cross bracing supports and blow snow onto the outside and allow to freeze {See Fig. 9}. After a few days the form work can be taken away to leave free standing corridors of ice.³ ~~The other way to build~~ is by cutting huge blocks of ice directly from an already frozen source, usually a nearby river. Ice is cut by industrial strength saws usually attached to heavy machinery, as some of the blocks can weigh upwards of two tons. Harvesting occurs in the spring and is stored until next year's use.

Ice has also been viewed as an advantageous material because of its extremely low cost of procurement and ease of manipulation, with its melting property seen as one of the key drawbacks. One experiment that sought to challenge ice's commonly perceived temporality

.....
2 Karlsson, Svenolof and Fredrik Emden. *Ice Age : The Hotel at the End of the World* {Stockholm, Sweden : Sellin & Partner Bok, 2002}

3 <http://www.icehotel.com/uk/ICEHOTEL/About-ICEHOTEL/How-we-build-ICEHOTEL/>

FIG. 10 : PYKRETE STRENGTH CHART



	ICE	CONCRETE	PYKRETE
COMPRESSION {PSI}	500	2,500	1,100
TENSION {PSI}	160	250	700
DENSITY {G/CM ³ }	.91	2.5	.98

was a project called the “HMS Habakkuk”⁴. During World War II, the English navy was running low on aircraft carriers, and England was running low on steel. British scientist Geoffrey Pyke came up with the idea to solve both problems with one fell swoop. His idea was to take an iceberg, insulate it on the outside, refrigerate it on the inside, and smooth its top to make a land able surface for planes. The prototype aircraft carrier, code named HMS Habakkuk after a biblical passage, had a number of advantages over standard carriers, namely its size and repairability. Not only does ice creation take one percent of the energy expenditure that it takes to create steel, but it is also seven times less dense, which would presumably allow the ship to float easier and be bigger in size⁵. The Habakkuk was planned to be over 4000 feet long, {almost four times the size of a Nimitz class super carrier, the largest warship to date} which meant that it could land larger planes such as bombers. It would also be able to withstand torpedoes from U-boats easier, as new ice could be quickly fused in place when the ship was

4 Lampe, David. *Pyke : The Unknown Genius* {London : Evans Brothers Limited, 1959}

5 Information obtained from : “The Physics Factbook” <http://hypertextbook.com/facts/>

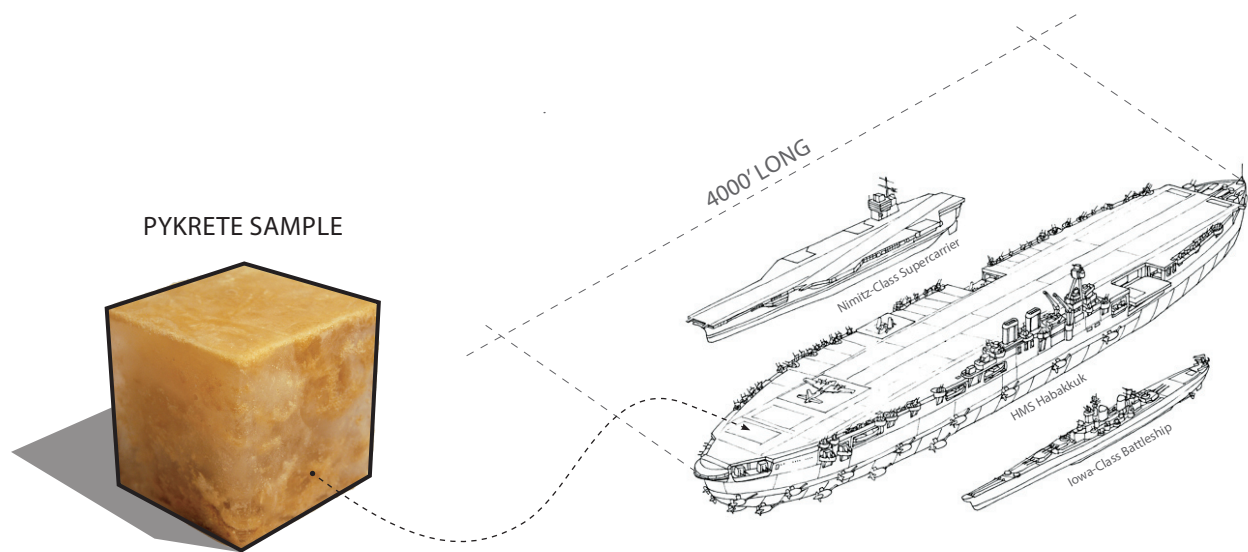

damaged. The project stalled however, because of the brittleness of ice, and it wasn't until the development of a material called "pykrete" that it was able to move forward again. Named after Geoffrey Pyke, pykrete is a combination of sawdust and water {ratio: 14% sawdust, 86% water} that is then frozen, producing an extremely strong form of ice. The newly created material had a higher tensile strength than concrete while remaining only half as dense, which made it even more ideal for structural use {See Fig. 10}. The British navy went so far as to have small mock-ups made in Canada of the aircraft carrier, though the project was eventually stopped because the war was drawing to a close and the constant melting of the pykrete being a big concern. Antarctica however, has the unique quality of always remaining below freezing temperature, thereby making pykrete an extremely plausible building material to consider.

Taking up where Pyke left off, the material exploration wing of T.A.N.A.A.C. has been conducting numerous experiments to test pykrete and ice for use as a suitable construction material in Antarctica, as well as in consultation with structural engineers for feasibility. Among

ICE/PYKRETE EXPERIMENTATION

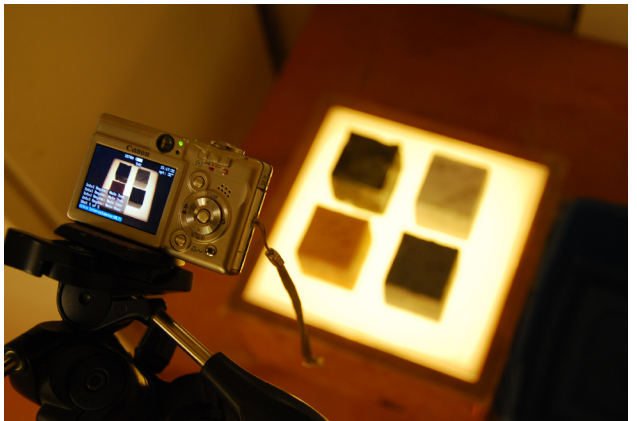
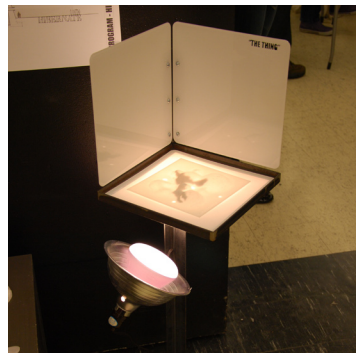
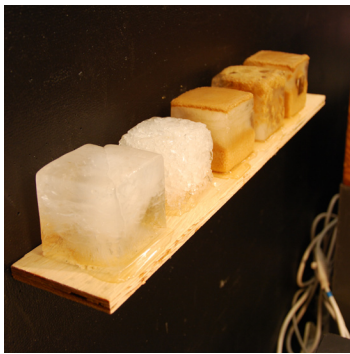

FIG. 11: STRUCTURE OF AN IGLOO

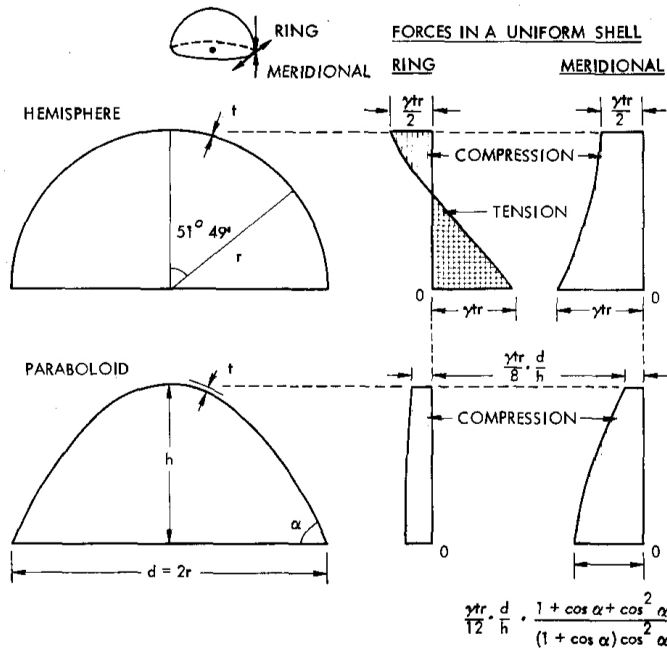

FIG. 1 Theoretical forces in two thin shells of revolution. Modified after Fischer (1960).

the testing done were studies into opacity {measuring the light qualities able to be transmitted through various pykrete mixture ratios}, embedding {how pykrete/ice reacted to insertion of other materials while freezing}, and melting points {pykrete has a slightly lower melting point than common ice, as well as takes longer to fully melt}. The testing concluded that pykrete would be an incredibly useful building material in Antarctica, allowing the required strength to form large vaults without lateral support, as well its relative low material and resource requirements. It can be cast or sprayed directly on site, and only an additive such as sawdust, wood pulp, or hemp fiber is required to give it its structural integrity.

As a stable structural form for ice, the igloo has long been accepted as the tried and true method for making a vault without interior support. What has only recently been established however, is that the Canadian Central Eskimos have actually been making their structures in the shape of a natural parabola in cross section, not the commonly thought spherical shape {see Fig. 11}⁶. With the use of pykrete's added compressive strength, and the use of the

6 Handy, Richard L. *The Igloo and the Natural Bridge as Ultimate Structures* {June 1, 2007}

FIG. 12: INFLATING FORM WORK FOR **ICE 9 SYSTEM**



parabolic form as a shape, vaults close to 70 to 80 feet wide could likely be safely maintained. **T.A.N.A.A.C.** is proposing use of a new construction technique, code named the **ICE 9 SYSTEM**, after the wonder material in *Cat's Cradle* by Kurt Vonnegut and the inflatable experimentations by architecture group Ant Farm⁷. The **ICE 9 SYSTEM** consists of an inflatable form work, powered and made possible by the **LIFE SUPPORT MODULES** delivered to site {see Fig. 12}. After the modules are hooked up to the generators and receiving power, air will be pumped into inflatable parabolic forms, needing only 0.5 psi⁸ to maintain rigidity during the next step in construction, the spraying!

The **ICE 9 SYSTEM** employs a similar technique to shotcrete, where concrete is sprayed onto forms from a large hose at a high pressure, actually compacting the concrete further and gaining strength from the force of the projection⁹. The difference in the case of the **ICE 9 SYS-**

.....
7 Lewallen, Constance M. and Steve Seid. *ANT FARM 1968-1978* {Berkeley, CA : University of California Press, Ltd., 2004}

8 Hurd, M. K. *Low Cost Concrete Storage Buildings* {The Aberdeen Group, 1997}

9 PDWAJV. *Shotcrete Lining of South Deep Shafts* {April 2001}



FIG. 13 : "ICE ISLAND" CONSTRUCTION

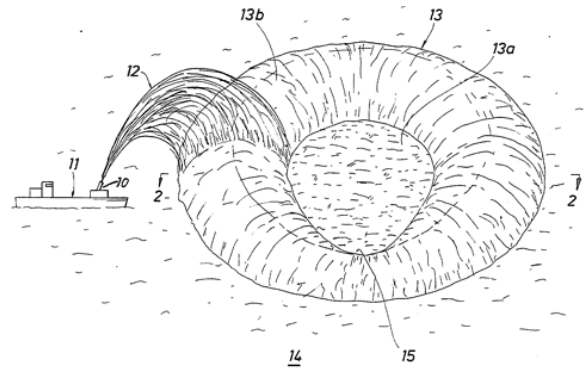

TEM is that *pykrete* will be used instead of concrete. Spray ice as a construction technique has been utilized in a myriad of different ways with successful results, but two examples that come to mind would be the construction of "ice hotels" and the creation of frozen islands for offshore oil drilling {See Fig. 13}. The case of ice hotels has been mentioned previously, but the creation of "ice islands" is another precedent that proves the plausibility of ice spray construction. In the 1970's and 80's oil companies interested in offshore drilling speculated about the possibility of creating artificial islands constructed solely of ice. In temperatures less than 20 degrees Fahrenheit, ice was sprayed into the air and built up until it reaches a thickened state. The ice islands could be built in a relatively quick amount of time, about two months, and grow upwards of 215 meters in diameter, 8 meters deep. Used to hold all of the cumbersome equipment for drilling, once they outlived their usefulness, they would just be left to melt back into the water from whence they came, creating a closed loop of material consumption.

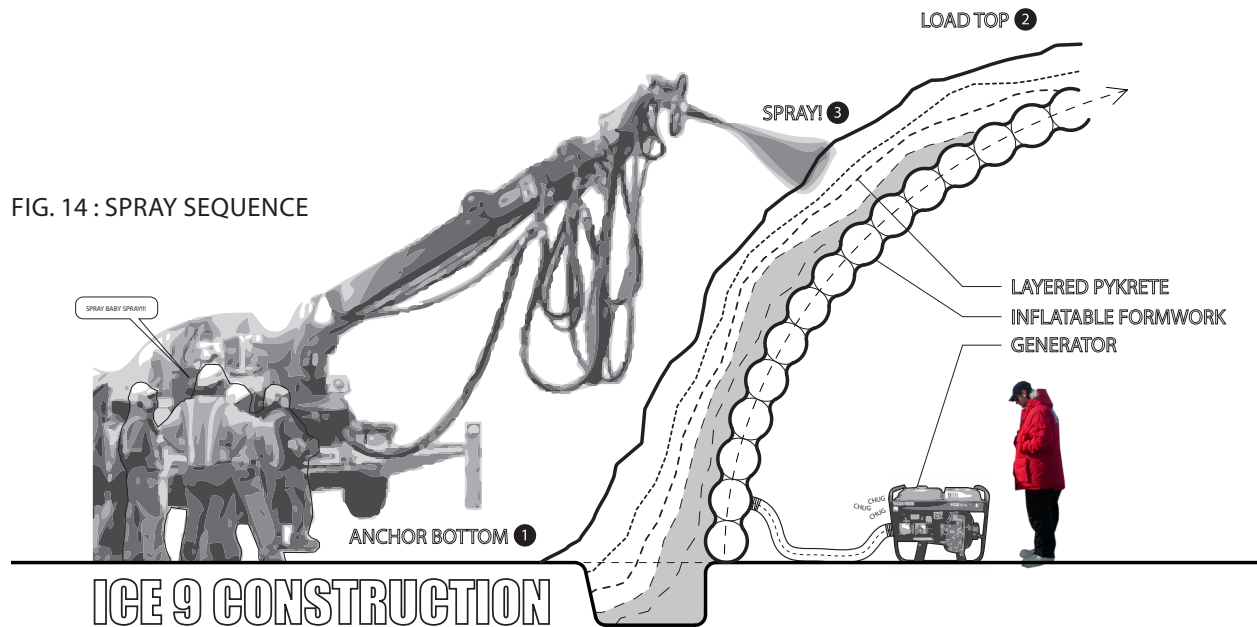
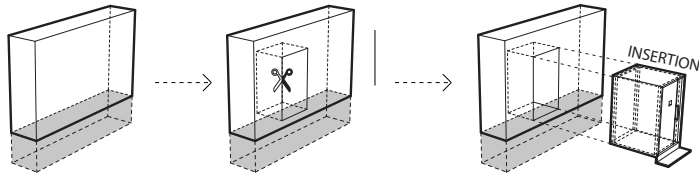

FIG. 14 : SPRAY SEQUENCE

On the **TERRA NOVA II EXPEDITION**, large free-spanning vaults will be made possible by spraying thin layer after thin layer of pykrete onto the inflated form work. In the actual spraying process, the base of the inflatable form work will first be anchored, securing it to the site and preventing wind from moving its positioning {see Fig. 14}. Next, the top of the form will be loaded to push out the side of the form work, since it is already held in place at the base, creating even more lateral rigidity in the inflatable {in preparation for the next step}. Finally, the layering process can begin by spraying pykrete from the high pressure hose onto the yet exposed form. Since the temperature is always below freezing, “curing” will occur rapidly, allowing for occupiable shelter within a matter of days, not years. Different ratios of water to sawdust {wood pulp} mixtures could also be used to achieve varying opacities and transparencies as program dictates. After the pykrete has set up, the form work can be removed and stored for future use as **HABITATION PODS**. To allow access, as well as increase transparency in different areas of the **ICE 9 SYSTEM**, thresholds and openings can be placed at strategic positions as program

FIG. 15 : EMBEDDING : TECHNIQUES



EMBEDDING : THRESHOLD

In most contemporary research stations in Antarctica, the separation between inside and outside is mitigated by conventional meat locker doors that you would find in any quasi-nice restaurant. One on side of the wall, sub zero temperature, on the other, 60+ degrees. With the **ICE 9 SYSTEM**'s ability to increase its thickness {and therefore it's insulation qualities} also comes the opportunity for a deeper threshold. Door components can be inserted into the thickened wall system with enough room inside to contain changing stations or temperature adjustment areas!

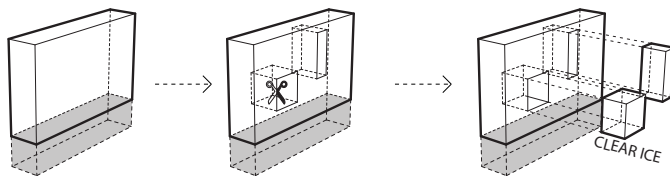
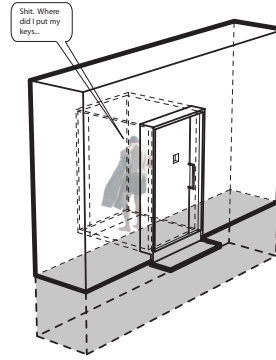

EMBEDDING : VIEW

Even though there are blizzards over half of the year, as well as pitch blackness for almost a third, keeping a connection to the incredible surrounding landscape can have enormous psychological impact. Once the **ICE 9 SYSTEM** is cast in place, small sections can be removed without fear for structural damage. Put back in place of the voids will be blocks of super-clear ice, excavated from the meters below the top surface crust. The ice at that depth has been compressed to almost pure transparency by the constant pressure of snow and ice above it, allowing for unobstructed views to outside while still using a locally available material.

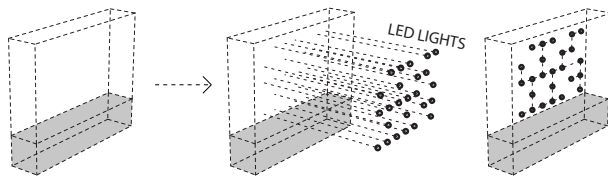
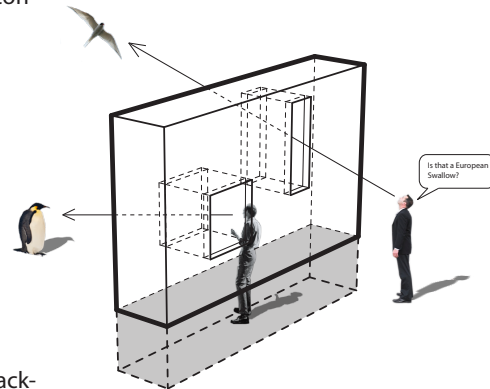

EMBEDDING : LIGHT

Day lighting in the conventional sense of the word has no real meaning down South. Roughly only half of the year receives light at all, and the summer light can be quite literally blinding outside, reflecting off of the white surface of the surrounding snow. To combat the months of darkness as well create a psychological environment, non-heat emitting LED's can be placed inside the **ICE 9 SYSTEM** before spraying, making the pseudo-interior/exterior spaces on the inside feel like outdoors even in the winter months, a notable advantage from a mental standpoint.

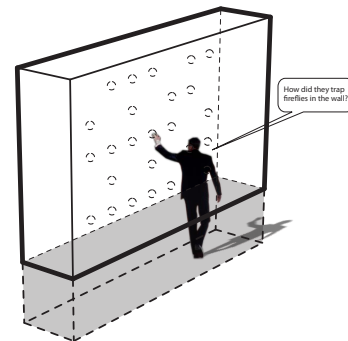
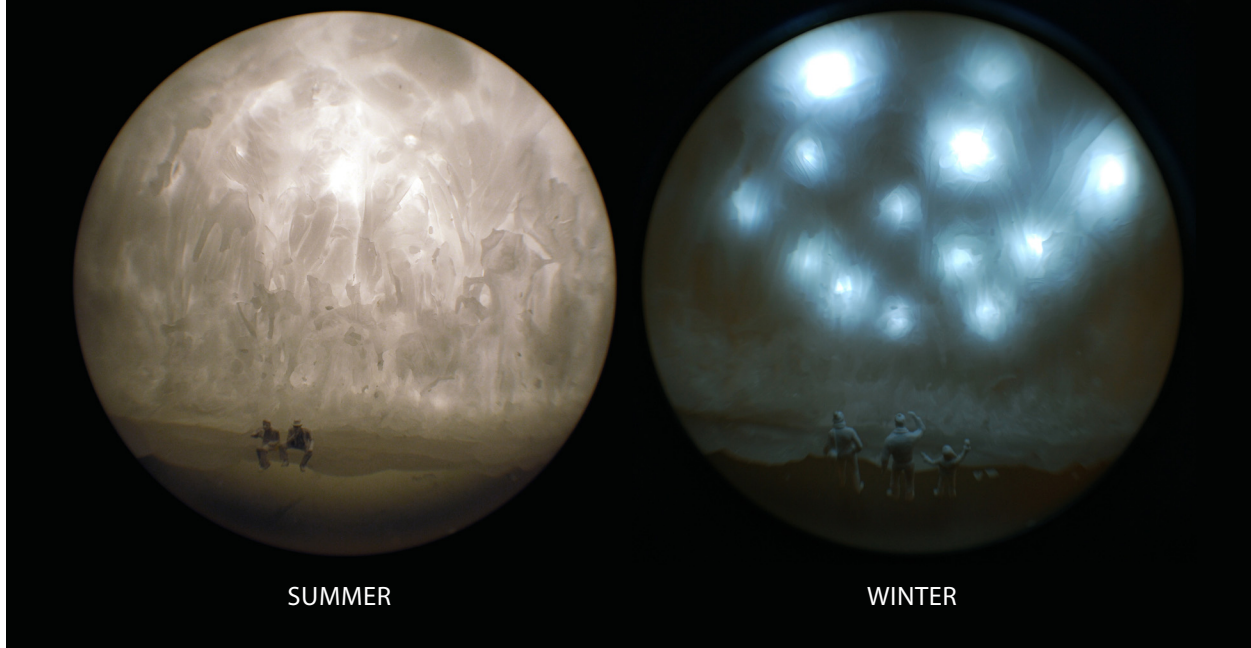

FIG. 16 : ARTIFICIAL LIGHTING



or light conditions dictate {see Fig. 15}. The thresholds can be deepened, unlike customary entrances to Antarctic stations, where a single meat locker door is all that separates outside from inside. Entries become spaces to occupy in the thickened wall system, allowing for changing of outside to inside clothes or storage. Psychologically, views to the outside on clear days, as well as artificial illumination on the dark days, are extremely important. Studies have shown that when scientists see the landscape on a daily basis, their moral notably improves¹⁰. With that notion in mind, cut outs can be made in the pykrete to allow for insertion of clear ice, harvested from meters below the top crust of snow, that will allow for higher levels of visibility inside and out. Artificial illumination is must also be drastically redefined in respect to mainland conventions, where daylight can be found at all times of the year, even in the winter. In the winter in Antarctica, months pass by without a sliver of light from the sun able to reach the stations, making artificial light completely necessary and ruling out standard forms of day lighting. In

.....
¹⁰ Slavid, Ruth. *Extreme Architecture: Building for Challenging Environments* (London, England : Laurence King Publishing Ltd., 2009)

response to this challenge, **T.A.N.A.A.C.** plans on embedding non-heat emitting LED's {Light Emitting Diodes} into the pykrete shield, thereby creating the feeling of exterior atmospheres, even when inside {see Fig. 16}. Overall, the **ICE 9 SYSTEM** serves to protect the inhabitants from the harsh weather conditions faced in Antarctica, as well as serving to mitigate between the interior and exterior temperatures, and preventing building deterioration.

{4} HABITATION PODS

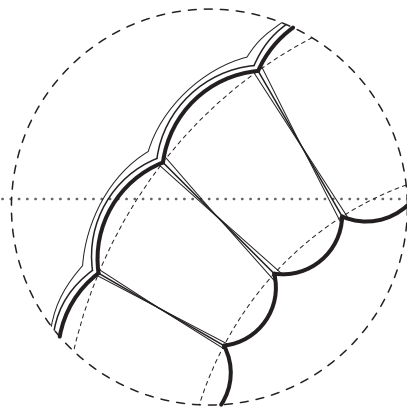

INFLATION OF **HABITATION PODS**



In order to be able to live in relative comfort in the coldest place in the world, we'll be bringing a series of inflatable structures down with us, code named "**HABITATION PODS**". Inflatables have never seriously been thought of as applicable to Antarctica because of the harsh wind conditions and risk of puncture. However, when combined with the **ICE 9 SYSTEM**, the pods will be shielded from direct contact with the outside elements, making their light weight and mobile nature extremely advantageous for our expedition purposes. To be even more efficient with the construction process, the inflatable system is designed in a way that allows the same material to be used not only as the form work for the **ICE 9 SYSTEM**, but is able to be compartmentalized and re-used again as **HABITATION PODS**! Once the spray ice has set in place, the form work can be taken apart into smaller segments via a system of built in zippers, allowing flexibility in the size and shape of the pods. Warm air from the **LIFE SUPPORT MODULES** is blown into the double membrane system, not only inflating the structure, but also heating the space inside, and retaining the warmth by a reflective outer layer.



Re-use of form work is an often overlooked possibility in the construction process. Usually form work is completely abandoned and regarded as waste that is meant to be hauled away. By utilizing the form work from one process as an actual building material used to inclose space saves valuable resources as well as regards the construction process as something that can actually designed and celebrated. One such project that investigates this commonly overlooked part of construction is Casa Poli, by Pezo von Ellrichschausen Architects. The house was built in 2005 out of mostly concrete with the use of unskilled labor. The 7 datums what were poured were all board formed concrete as a technique. What is different in the case of Casa Poli is that instead of throwing all of the wood away that was used to pour the concrete into, it is reused inside of the house as interior furniture. The form work was sanded down to remove the roughest of the remnants of casting and then painted white as well as the interior concrete, further blurring the line between casting material and cast. Similarly, the **HABITATION PODS** will seek to conserve resources by re-using usually destroyed parts of the construction process.



ANT FARM INFLATABLE : SINGLE MEMBRANE



INFLATOCOOKBOOK



KENGO KUMA TEAHOUSE : DOUBLE MEMBRANE

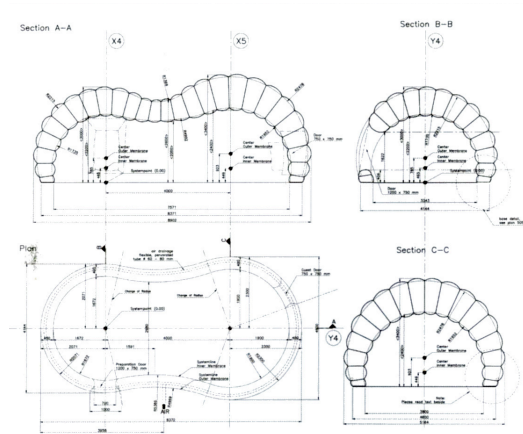

The pods are made up of a double membrane wall system that effectively traps heat from the warm air pumped in by the LIFE SUPPORT MODULES. Single membrane systems, such as the structures made possible by the Ant Farm's Inflatocookbook¹, though easy to build and maintain, also require special thresholds to regulate correct air pressure from inside to outside, and are generally not very durable or long lasting. To achieve their stringent demands for rigidity as well as durability, the members of **T.A.N.A.A.C.**'s inflatable technology department turned to the precedent of a double membrane structure by the Japanese architect Kengo Kuma for their inspiration behind the **HABITATION PODS**. Double membrane inflatable structures offer the advantage of not having to make up the pressure differentials between inside air and outside air, because the air is contained in between two layers of plastic, also needing less

.....
¹ Lord, Chip. *Inflatocookbook* {San Francisco, CA : Ant Farm, 1971}

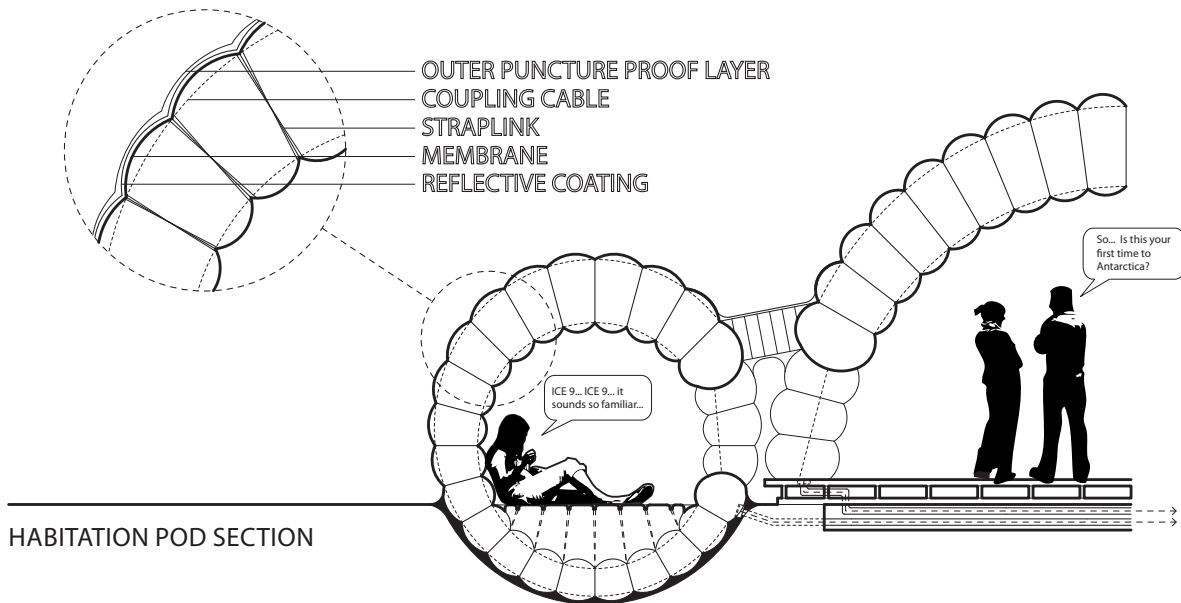

energy and air to stay inflated. Kuma's teahouse made for the Kunst Museum in Frankfurt is not only a double membrane wall construction, but it also is movable, able to be taken down and erected in a relatively short amount of time, just a few hours with a small team². The teahouse is able to be powered by an incredibly small 1.5 kilowatt {2 horsepower} compressor which blows warm air into the wall cavity, an effective way to mitigate the temperature difference between inside and outside. On top of that, LED's are also embedded within the wall construction, again allowing artificial illumination without visibly being able to see the source of light {See Fig. 18}.

The main challenge the **HABITATION PODS** are designed to overcome is : how to create a comfortable long term inhabitation with minimal time and resources? Inflatable structures are not only incredibly quick to erect, but will not be subject to any of the normally damaging wind and snow conditions that other Antarctic buildings have to deal with because of protec-

.....
 2 Fischer, Volker and Ulrich Schneider {Eds.}. *Kengo Kuma : Breathing Architecture* {Basel, Switzerland : Birkhuser Verlag AG, 2008}

FIG. 17 : TERRA NOVA II PROGRAM GUIDELINES

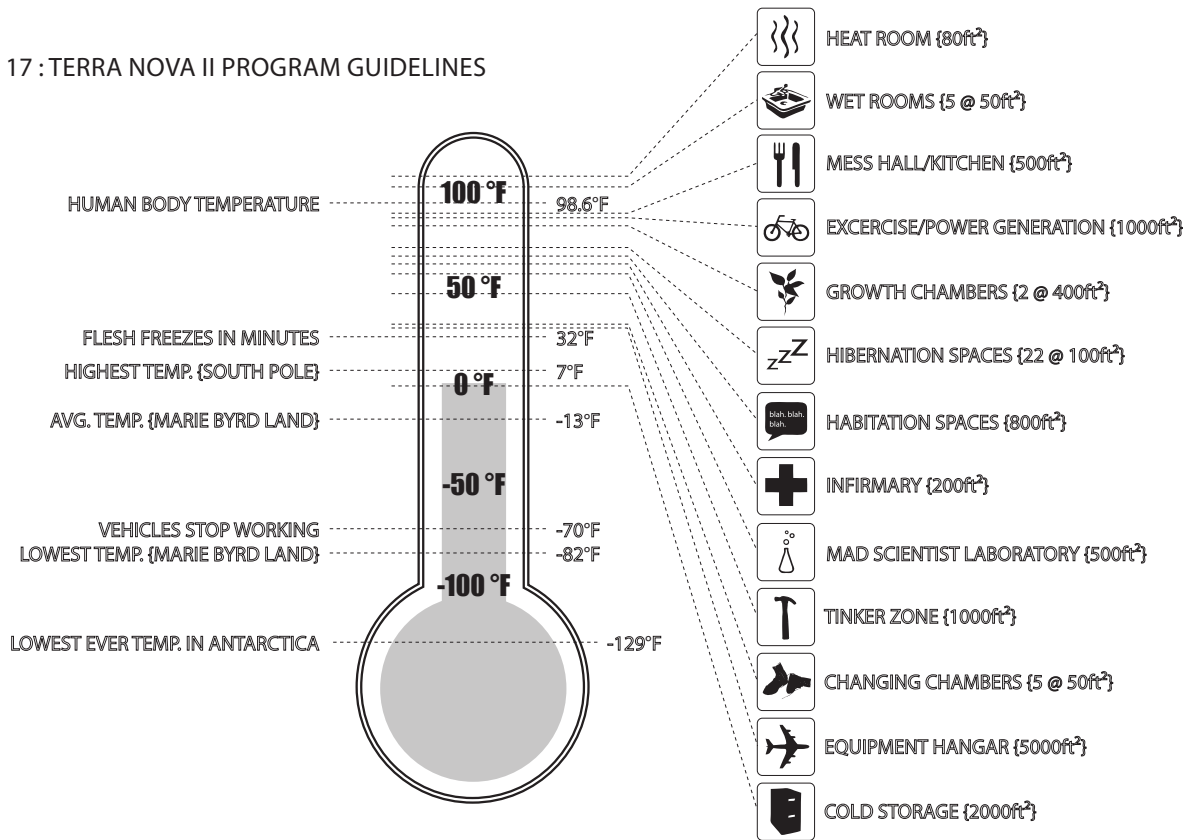

tion from the **ICE 9 SYSTEM**. The outer layer of pykrete will serve to bring down the temperature to a manageable 32 to 55 degrees Fahrenheit {versus the possible -70 outside}, and the **HABITATION PODS** can bring the temperature up to 65-70 degrees Fahrenheit with little effort. Different programs maintain heat in different ways, with some such as bathing and kitchen generating high levels of warmth in the areas that surround them. Other programs, such as storage and workshop space, can afford to be at lower temperatures because of their latency and the embodied energy present in the activity, respectively. By correlating programmatic issues to temperatures rather than square footages and adjacencies, space can be thought of in a completely new way of understanding {See Fig. 17}.

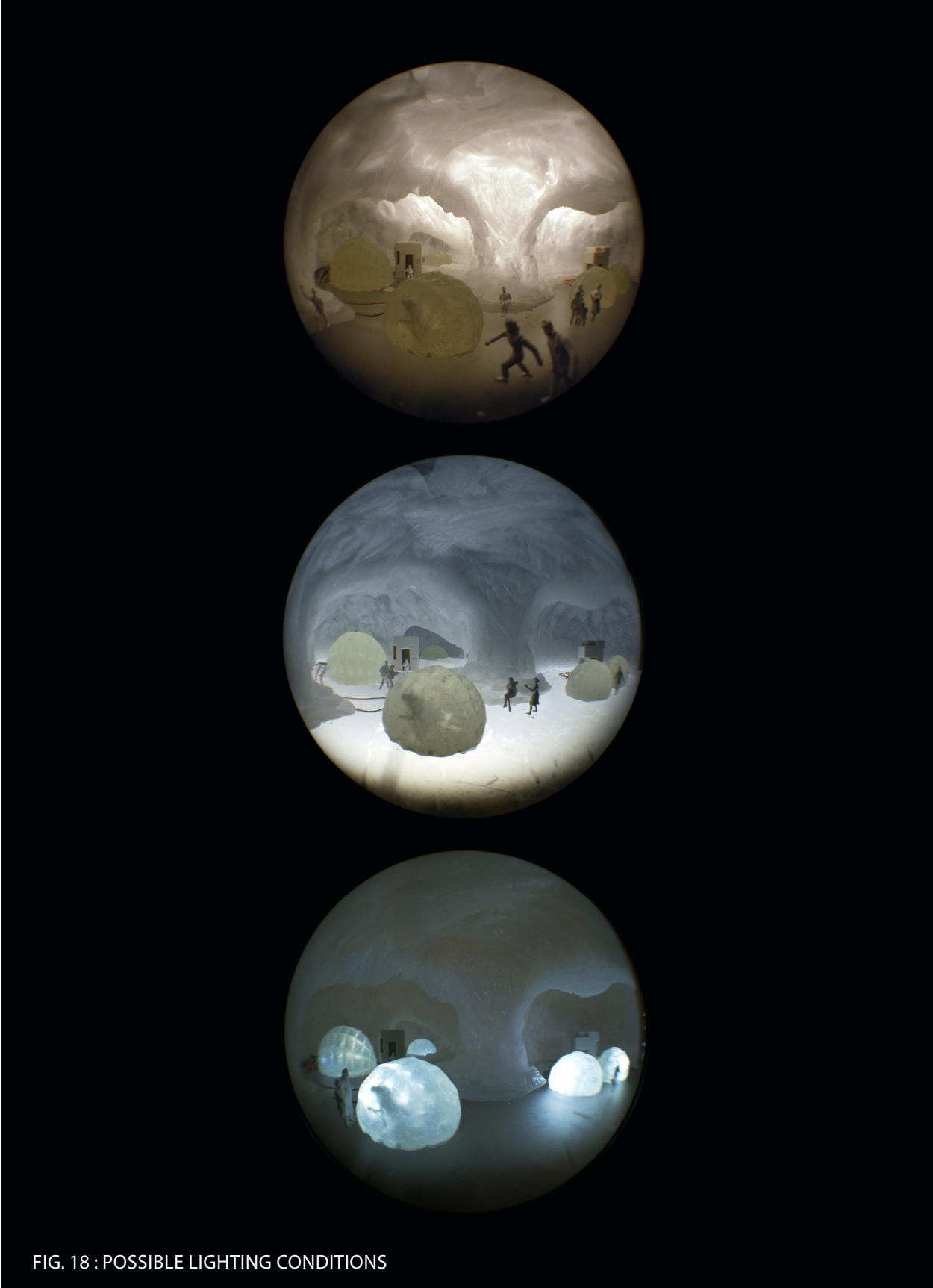

FIG. 18 : POSSIBLE LIGHTING CONDITIONS

{5} THE ARK

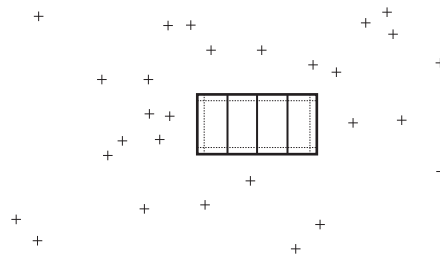
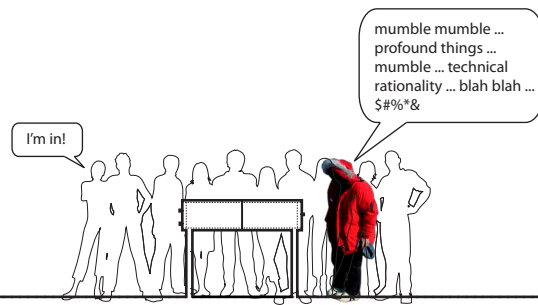
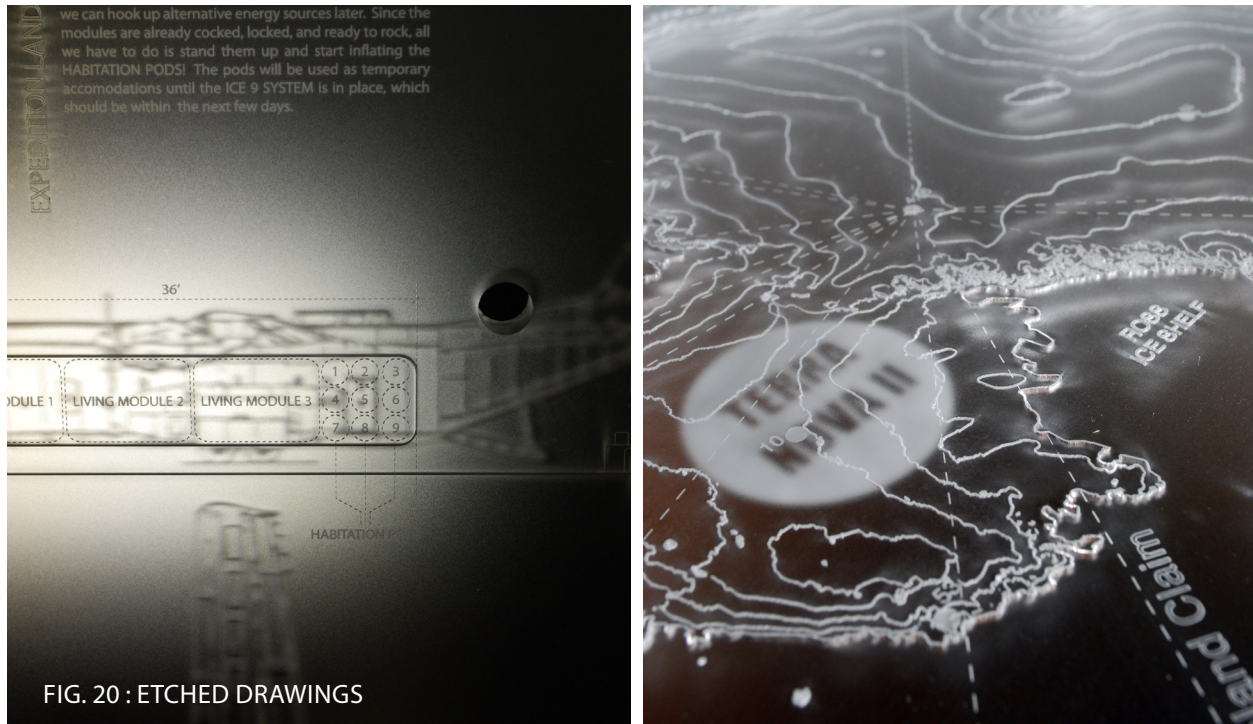



FIG. 19 : "THE ARK"

How best then to present the ideas mentioned in previous pages to a captive audience, and presumably get funding for future expeditions? This was the question **T.A.N.A.A.C.** asked, and in answer sub-contracted Berkeley student and **T.A.N.A.A.C.** member Taylor Medlin to come up with a way to visualize the information regarding future Antarctica construction techniques. His solution? The **"ARK"** {See Fig. 19}. A presentation cabinet made out of steel angle for the structure and matte-finish acrylic for the sides and top. It contains all of the necessary data and drawings laser etched onto the exterior faces, while hiding all of the spatial representations of possibilities inside.

Lit from inside by fluorescent tubing, the outside acrylic glows to portray foggy allusions to the models hidden away. Like an ancient tomb encrusted with hieroglyphic markings, the drawings are digitally carved onto the faces by use of an ILS "etching" laser-cutter. All of the site analysis, precedent research, and details are contained in the drawings, and tell the story of conception and process, onwards to the ultimate final presentation. By using single sided



matte 1/4" acrylic panels, the drawings are able to remain crisp and legible on the exterior face, while etchings on the backside appear as fuzzy backdrops, further adding to the depth of the display {See Fig. 20}. Visually, the bright, almost blinding white light of the fluorescent lights and the neutral transparency of the acrylic panels harken back to the material properties of ice, transporting the viewer into the atmosphere of Antarctica.

The interior world of the **ARK** is populated by the various atmospheres and models meant to provide an understanding of the process of construction, going all the way from transportation of **LIFE SUPPORT MODULES**, to the inflation of the **HABITATION PODS**. While the drawings remain perfectly legible for viewing, the exterior of the models can never be seen from outside, becoming only ghosted abstractions of what truly exists inside the cabinet. In the same way that context does not exist normally in Antarctica {no neighbors, blizzards for half of the year dramatically reduce visibility}, the normally coveted exterior views of architectural models are no longer necessary or useful. Where the inhabitants will spend the majority of their

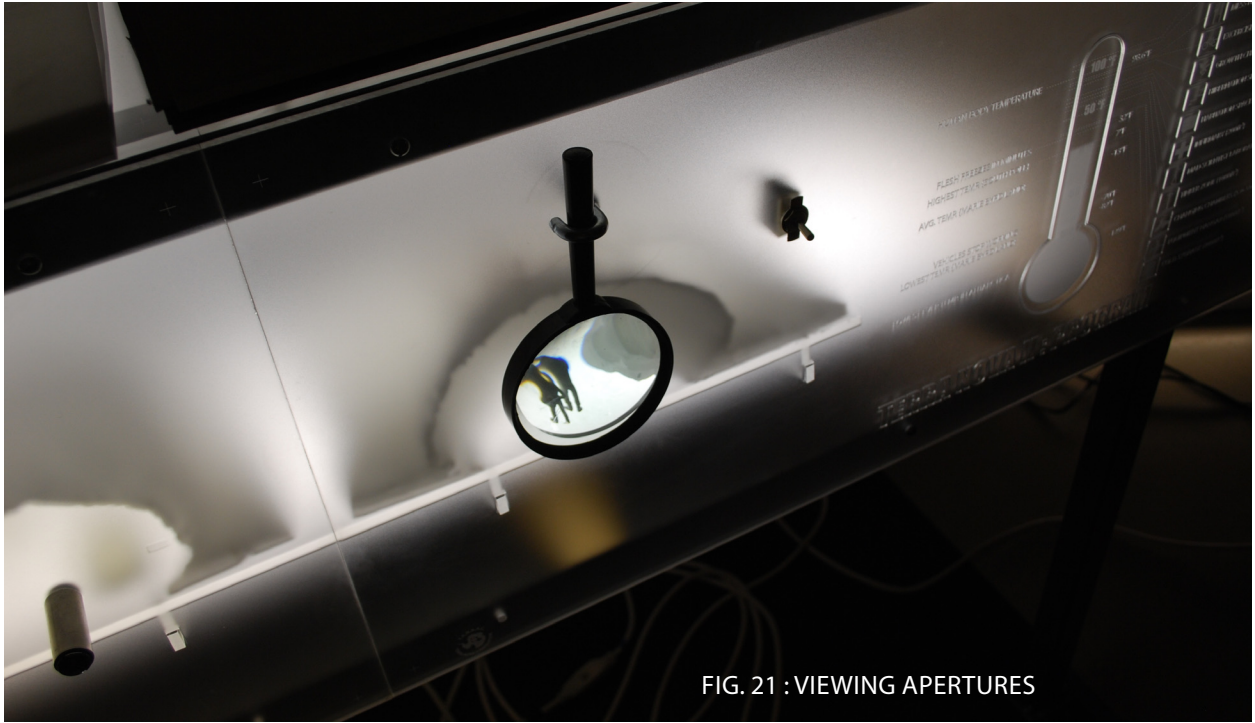
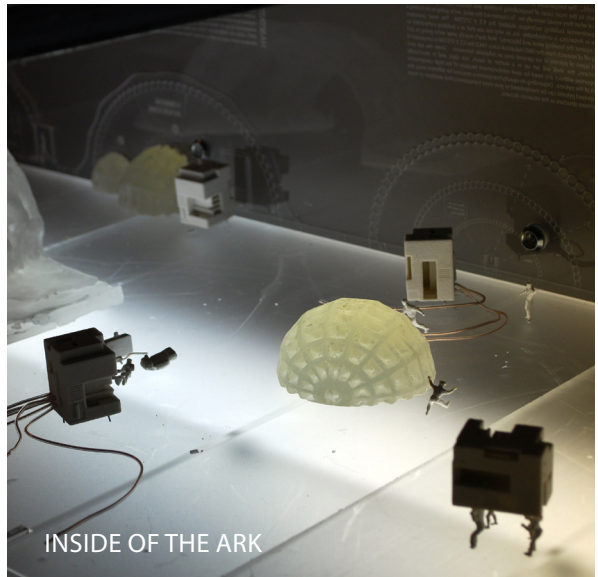

FIG. 21 : VIEWING APERTURES



FIG. 22 : DOOR PEEPHOLES



INSIDE OF THE ARK

time is inside of the structures, therefore portraying the atmospheres possible in the interior becomes of much more importance. To draw the common passerby {and future **T.A.N.A.A.C.** member} into the world of Antarctic possibilities, a series of apertures are placed on the side of the **ARK** to allow views in {See Fig. 21}. Common off the shelf door peepholes are used so that only when right up next to the presentation will you be able to experience it visually, necessitating a heightened interaction and sense of wonder and surprise. By looking through the small lens, a 180 degrees view is possible, showing different stages of the construction process {See Fig. 22}. Also present are a series of magnifying glasses, where more direct views in are allowed to further comprehend the different spatial possibilities outlined in the presentation.

Built on castors, with a projector housed within the chase, the **ARK** is meant to expand the conversation of possible construction techniques through exhibition at various colleges and galleries nationwide. By coming up with an engaging visual portrayal of the situations proposed through the three part construction process, further funding as well as members could be procured over the months and years ahead!



EPILOGUE : A NEW FUTURE



What does the future hold for Antarctica? If nothing is done different from the way construction has been handled so far, the outlook appears bleak. Imagine a continent populated by ice and ruins of structures not deemed worthy to be hauled off-site, polluted by its continual use of resource-heavy diesel generators and machinery. What the **TERRA NOVA II EXPEDITION** wishes to propose is a different future, one with renewable resources used for efficiency and power, an emphasis on quickness and lightness instead of solidity and long construction times. The three novel construction typologies proposed, **LIFE SUPPORT MODULES**, **ICE 9 SYSTEM**, and **HABITATION PODS** are just one way to go about making Antarctica not only habitable, but sustainable through building and emphasis on local materials. Other architects and artists are also looking ahead, conjuring up their own views of Antarctica habitation and what they believe could be possible.

One such architect, David A. Garcia, used his inaugural publication of the research resource entitled MAP {Manual of Architectural Possibilities} to explore future Antarctic endeav-

FIG. 23 : MAP BY DAVID GARCIA



ors¹. Among his proposals are “Ready Made Antarctic Base Stations” made from retired LC-130 airplanes, a “Sustainable Iceberg Living Station” constructed by a single hydraulic excavator mining out an iceberg, and an “Ice Flow and Sea Current Research Unit” that moves with the glacier and eventually is buried and deposited into the ocean {See Fig. 23}. Garcia understands the importance of coming up with never before thought of techniques for building in extreme environments, as does Peter Cook, when he wrote in the introduction to MAP, “So here we are with the territory of the virtually unknown. The last continent. The last hope?”

The time is now! A call to arms for architects and designers to get involved in areas that we have previously been shut out of, space shuttles, arctic stations, deep sea underwater living habitats. These are projects that have notoriously been left up to engineers and scientists

1 Garcia, David. *MAP: Antarctica* [David A. Garcia, 2009]

to figure out, and they have, but we know that the first way is not always right, and requires a constant challenging if we are to create a world that lives off of renewable resources and a connection to natural materials and therefore nature. In the famous words of the late Sambo Mockbee, "If you're going to do this, you gotta pack your bags, kiss your wife goodbye, and go to war."



IS THIS THE END?
NO... THE BEGINNING.

IMAGE SOURCES

The Wanderer {iv}	http://adamfcornford.wordpress.com/2009/03/16/
Scott Expedition {1}	http://www.spri.cam.ac.uk/museum/exhibitions/scot-letters/P48_281_11.jpg
Helicopters {6}	photography by Stephen Loiacono
Palmer Station {9}	http://cleancutamericankid.com/page/3/?archives-list=1
Snow Cat {9}	http://blogs.jcvi.org/tag/gos/
LC 130 Offloading {13}	http://www.southpolestation.com/9899/99photos1.html
HERC LC 130 Drawing {13}	http://richard.ferriere.free.fr/3vues/c130_3v.jpg
Completed Halley VI Module {14}	http://www.antarctica.ac.uk/living_and_working/research_stations/halley/halleyvi/images/karl_with_module.jpg
Halley VI Skis {14}	http://www.theengineer.co.uk/pictures/web/images/19130.gif
Amundsen Scott Station {15}	http://www.southpolestation.com/0708/aerials/spring1.html
Dymaxion House - Fuller {16}	http://tjcaia.com/blog/wp-content/uploads/2008/12/dymax.jpg
Tropical Housing - Prouve {16}	http://4.bp.blogspot.com/_5hqBYPQYY0I/Sw9gwpL8-hYI/AAAAAAAAArU/tWRY7Np_2Ag/s640/houseTropicalNigerCongo
Loblolly House {17}	http://www.architectmagazine.com/Images/tmp-B7AD.tmp_tcm20-168611.jpg

Ice Palace {20}	http://kathika.com/wp-content/uploads/Icehouse_1878.jpg
Ice Hotel Formwork {21}	Karlsson, Svenolof and Fredrik Emden. <i>Ice Age : The Hotel at the End of the World</i> {Stockholm, Sweden : Sellin & Partner Bok, 2002}
Ice Cutting {21}	Karlsson, Svenolof and Fredrik Emden. <i>Ice Age : The Hotel at the End of the World</i> {Stockholm, Sweden : Sellin & Partner Bok, 2002}
HMS Habbakuk {23}	http://surcandoloscielos.es/blog/el-portaaviones-de-hielo/
Igloo Diagrams {25}	Handy, Richard L. <i>The Igloo and the Natural Bridge as Ultimate Structures</i> {June 1, 2007}
Ice Islands {27}	http://infranetlab.org/blog/2010/02/islands-of-speculation-speculation-on-islands-spray-ice/
Ant Farm Inflatable {35}	http://farm3.static.flickr.com/2016/2502417965_d0b5f5cd92.jpg?v=0
InflatoCookbook {35}	http://www.boutiquevizique.com/etcetera/content/_Z_/inspiratie/artistieke_projecten/Ant_Farm/InflatoCookbook/AntFarmInflatocookbook9-Phot.jpg
Kengo Kuma Teahouse {35}	Fischer, Volker and Ulrich Schneider {Eds.}. <i>Kengo Kuma : Breathing Architecture</i> {Basel, Switzerland : Birkhduser Verlag AG, 2008}
HERC Landing {46}	http://polarfieldservice.wordpress.com/2009/11/
MAP : Garcia {47}	http://2.bp.blogspot.com/_1l-OTBH3k9E/S-0fOYOpa-CI/AAAAAAAAAnA/bHVSXPyaviw/s1600/03.jpg

WORKS CITED

Curtiss, Mina Kirstein. *A Forgotten Empress: Anna Ivanovna and Her Era, 1730-1740* {New York, New York : Ungar Publishing, 1970}

Fischer, Volker and Ulrich Schneider {Eds.}. *Kengo Kuma : Breathing Architecture* {Basel, Switzerland : Birkhduser Verlag AG, 2008}

Garcia, David. *MAP : Antarctica* {David A. Garcia, 2009}

Handy, Richard L. *The Igloo and the Natural Bridge as Ultimate Structures* {June 1, 2007}

Hurd, M. K. *Low Cost Concrete Storage Buildings* {The Aberdeen Group, 1997}

Karlsson, Svenolof and Fredrik Emden. *Ice Age : The Hotel at the End of the World* {Stockholm, Sweden : Sellin & Partner Bok, 2002}

Kieran, Stephen and James Timberlake. *Loblolly House* {New York, New York : Princeton Architectural Press, 2008}

Lampe, David. *Pyke : The Unknown Genius* {London : Evans Brothers Limited, 1959}

Lewallen, Constance M. and Steve Seid. *ANT FARM 1968-1978* {Berkeley, CA : University of California Press, Ltd., 2004}

Lord, Chip. *Inflatocookbook* {San Francisco, CA : Ant Farm, 1971}

PDWAJV. *Shotcrete Lining of South Deep Shafts* {April 2001}

Piantadosi, Claude E. *The Biology of Human Survival: Life and Death in Extreme Environments* {New York, New York : Oxford University Press, Inc., 2003}

Sieden, Lloyd. *Buckminster Fuller's Universe: His Life and Work* {New York, New York : Basic Books, 2000}

Slavid, Ruth. *Extreme Architecture: Building for Challenging Environments* {London, England : Laurence King Publishing Ltd., 2009}

Von Vegesack, Alexander. *Jean Prouve: The Poetics of Technical Objects* {Vitra Design Stiftung, 2005}

Yankielun, Norbert E. *How to Build an Igloo* {New York, New York : W. W. Norton & Company, 2007}